

CARACTERÍSTICAS TÉCNICAS | Technical Characteristics

MATERIAL Aço e madeira termotratada
ACABAMENTO Aço Metalizado e Pintado (Cores Corten ou Antracite, texturados) Madeira com velaturas de protecção e acabamento
COLOCAÇÃO Em base rígida
PESO APROX. Aprox. 52 Kg

MATERIAL Steel and thermo-treated wood
FINISH Tinned and painted steel (Corten/Anthracite textured colors) Wood with protection and finishing varnishing
FIXING Set to rigid pavement
WEIGHT Approx. 52 Kg



DESIGN Dep. Técnico AMOP

Dimensões (mm)

DESENHO TÉCNICO | Technical Drawing

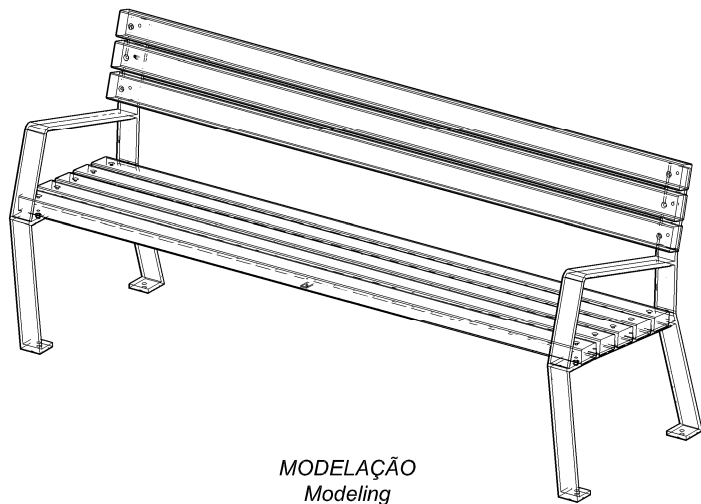

MODELAÇÃO
Modeling

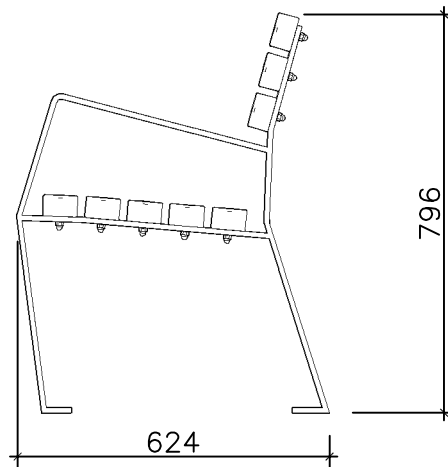

ALÇADO LATERAL
Side View

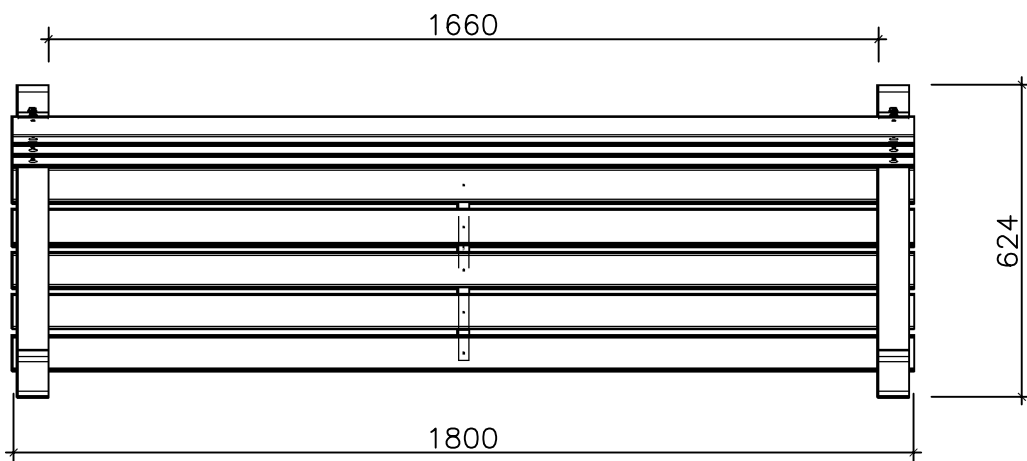

PLANTA
TopView

APLICAÇÃO | Installation

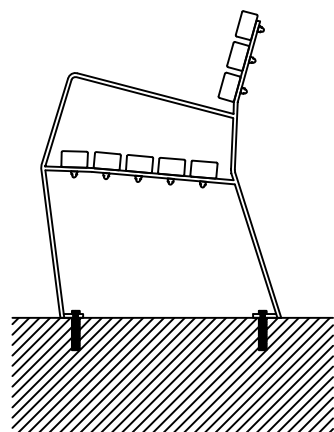

BUCHA METALICA M10 (INCLUIDO)
M10 EXPANSION BOLT (INCLUDED)

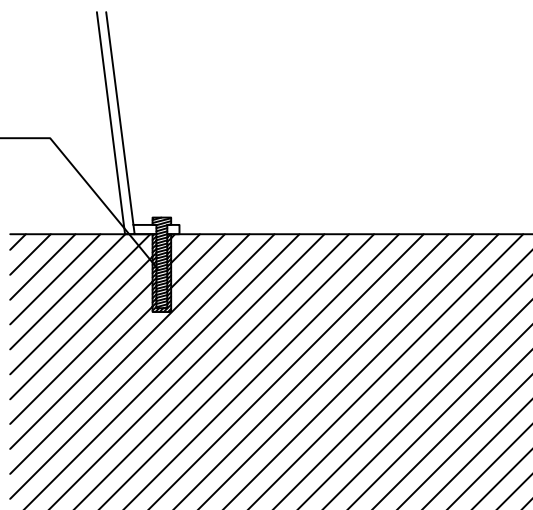

APLICAÇÃO COM 4 BUCHA METALICA M10 (INCLUIDO)
INSTALLATION WITH 4 M10 MECHANIC ANCHORS (INCLUDED)

PARAFUSOS PARA MADEIRA EM INOX
STAINLESS STEEL WOOD CONNECTION BOLTS

CADEIRA COLECTIVA 2A

AMP.019/00 EDIÇÃO 0 DATA: 20-05-2011



APARTADO 38 3754-906 AGUADA DE BAIXO ÁGUEDA - PORTUGAL
 TEL 234667957 FAX 234666908
 ecn2@grupoamop.com www.ecn2.eu

REF.^a - 13056

FT.13056 Folha | Page 1-1